

	This symbol indicates that dangerous voltage constituting a risk of electric shock is present within this unit.
	This symbol indicates that there are important operating and maintenance instructions in the literature accompanying this unit.

	CAUTION	
RISK OF ELECTRIC SHOCK, DO NOT OPEN!		
CAUTION: TO REDUCE THE RISK OF ELECTRIC SHOCK, DO NOT REMOVE COVER. NO USER SERVICEABLE PARTS INSIDE. REFER SERVICING TO QUALIFIED SERVICE PERSONNEL		

THIS INSTALLATION SHOULD BE MADE BY A QUALIFIED SERVICE PERSON AND SHOULD CONFORM TO ALL LOCAL CODES. READ AND FOLLOW THE SAFETY INSTRUCTIONS BEFORE ATTEMPTING THIS INSTALLATION.

NOTE to CATV system installer: This reminder is provided to call the CATV system installer's attention to Article 820-40 of the NEC that provides guidelines for proper grounding and, in particular, specifies that the cable ground shall be connected to the grounding system of the building, as close to the point of cable entry as practical.

GUIDELINES

- A. **LOCATION** – Make certain that the wall bracket mounting location allows for rear coax cable and ground wire entry through the wall to the back of the wall casting. Also position the wall bracket at a mounting height of 47±2 inches. See Figure 1.
- B. **WALL STRENGTH** – The wall bracket mounting instruction cover the most desirable mounting method, back-to-back bracket mounting, plus some other recommended methods depending upon wall construction. **IN ALL CASES** the wall construction must be able to support a minimum loading of **350 PSI** applied perpendicular to the mounting hole locations by compression or tension. Some wall construction may require internal bracing to accept the minimum loading required.
- C. **HARDWARE REQUIREMENTS** – Use the following hardware for all wall bracket installations. Hardware is NOT supplied with the wall bracket.
 - 1. All threaded rods, bolts or machine screws will be ¼" -20UNC-2A thread or equivalent.
 - 2. The back-up plate is a 6-1/2" x 10", 11 gauge metal plate, with four 9/32" holes that coincide with the wall bracket. A pre-fabricated backing plate, PDI-218, is available directly from PDI.
 - 3. All threaded rods will be finished off with an acorn nut.
- D. **TOTAL WEIGHT** of the PDI 9" receiver and support arm system is 41 pounds approximately.

Coax Cable From Central PS

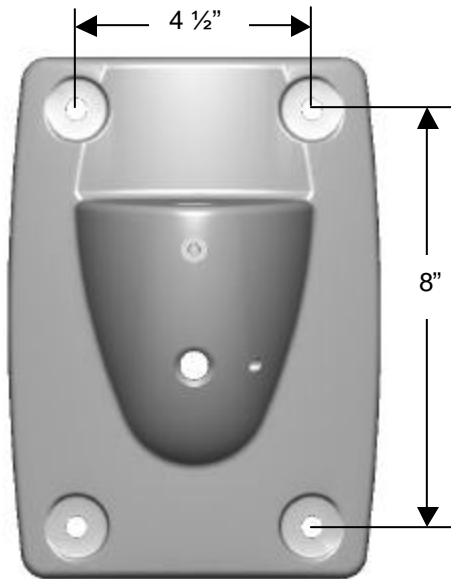
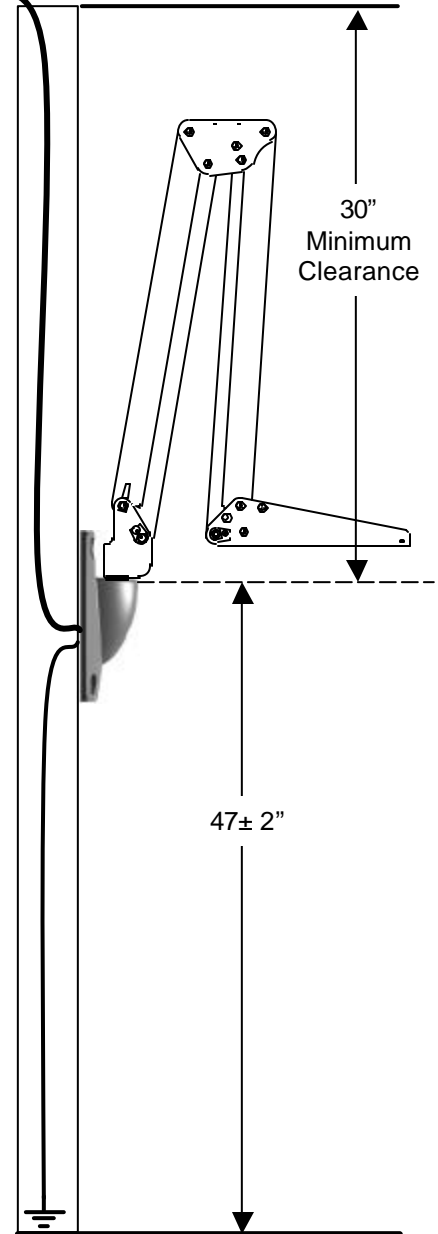

Mounting Hole Pattern
Front View



Grounding Screw
Rear View

BACK-TO-BACK MOUNTING

Refer to Figure 2.

1. Position the mount so the bolt pattern straddles an interior wall stud and allows for rear coax cable and ground wire entry through the wall to the back of the wall casting. Adjust the mounting height to a distance of 47 ± 2 " from the floor to top of pivot hole as shown in figure 1. It is also important that the mounting location be approximately 15" from the patient's bed. Please note also that the suspension arm requires a minimum clearance distance of 30" from ceiling to the top of the wall bracket. A check with the contractor/architect or Hospital Engineering Department regarding hidden objects behind the wall should be made before proceeding with this installation and final operation of the arm assembly.
2. Place a spirit level along the top surface of wall mount pivot hole and adjust for a true horizontal position. Then mark the location of the mounting holes.
3. Drill the top holes completely through the wall with a $9/32$ " bit.
4. Drill the bottom mounting holes half-way through the wall and complete the holes from the opposite side. NOTE: All holes must be drilled perpendicular to the wall so that they are spaced 4-1/2" on horizontal centers and 8" on vertical centers on the opposite side of the wall.
5. Route the coax through the front opening and secure the ground wire. Place a hex nut $5/16$ " on one end of each $1/4$ " threaded rod through the top mounting holes and through the top wall holes. Hold the wall bracket and rods in place and have an assistant fasten the mounting bracket in the opposite wall through the top holes using hex nuts. Tighten the nuts to a snug fit.
6. Cut the threaded rods $5/16$ " from the outside surface of the hex nut. Install and tighten cap nuts on rods.
7. Insert the additional threaded rods through the bottom mounting holes. Fasten, cut, and finish the rods as previously described in steps 5 and 6.

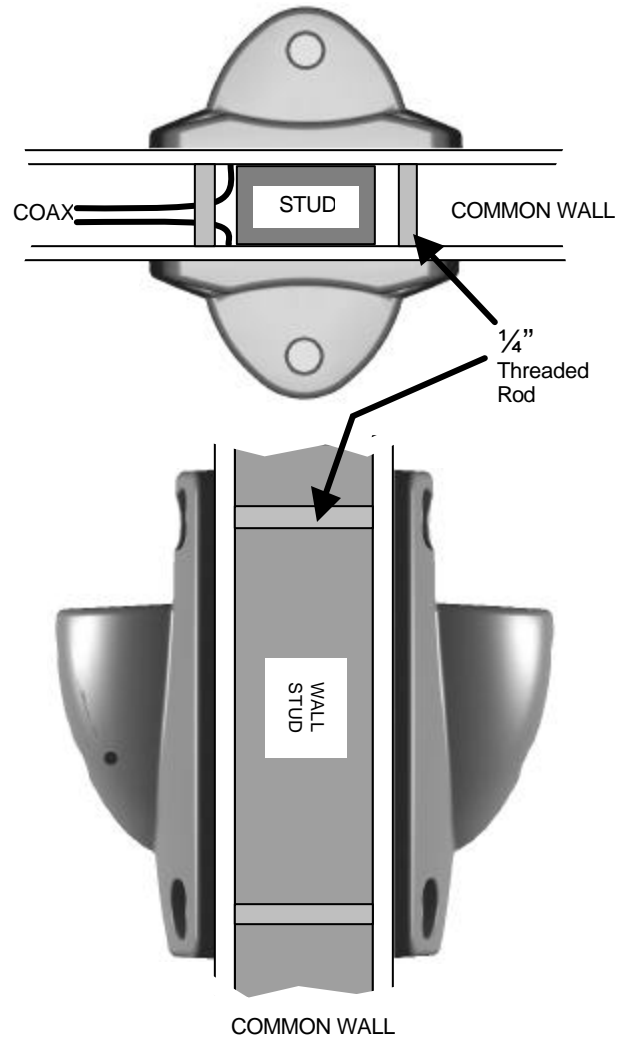

Figure 2.

Wiring Not Shown for Clarity

BACK-UP PLATE MOUNTING

Refer to Figures 3 and 4.

1. Complete the first four steps 1 through 4 as previously describe under "BACK-TO-BACK MOUNTING."
2. Route the coax through the front opening and secure the ground wire. Place a hex nut $5/16$ " from one end of threaded rod. Tighten cap nuts on rods so that the nut faces are even. Insert the threaded rods through the top and bottom mounting holes.
3. Hold the rods in place and have an assistant place and secure the back-up plate on the opposite wall using hex nuts. Cut the threaded rods $5/16$ " from the outside surface of the hex nuts. Install and tighten cap nuts on rods.

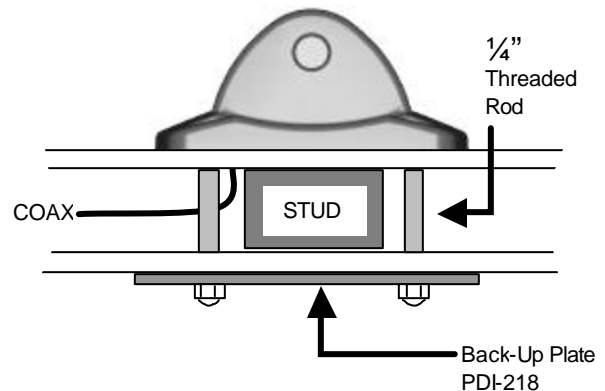

Figure 3.

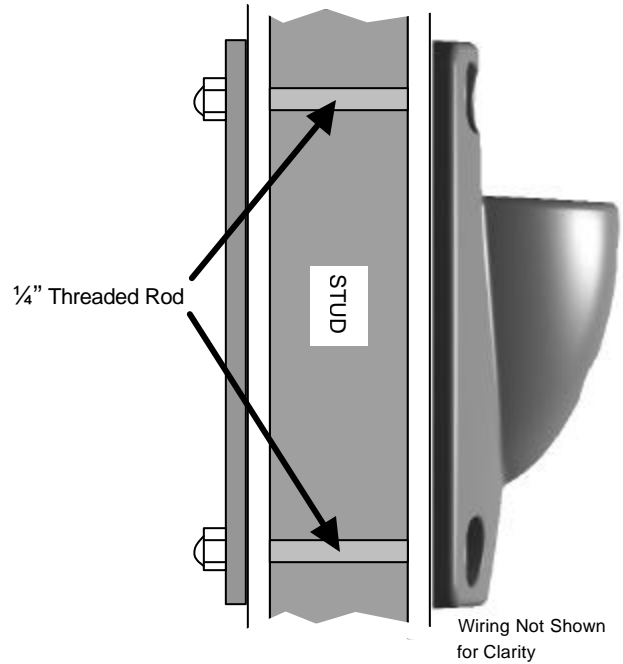
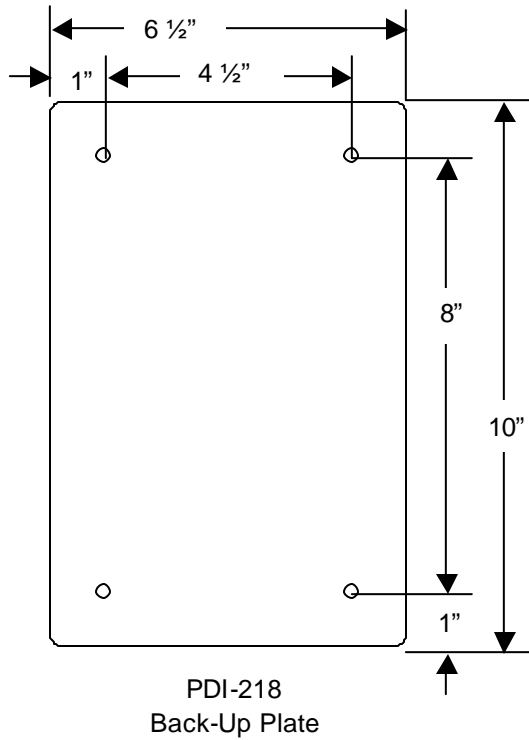

Figure 4.

OTHER MOUNTING METHODS

There are other methods to mount the wall bracket, but the **PREFERRED** mounting is a back-to-back system or back-up plate system as described. The mounting method used must meet the requirements as described in **GENERAL GUIDELINES**. The following mounting methods may be used if the previously listed precautions are adhered to.

- SOLID CONTRUCTION WALLS** – Concrete, brick, and some types of cement block, cement expansion anchors can be used.



Special tests should be performed on the wall before installation of the expansion anchors in the area of the bracket mounting location. Proof test the load for the anchors to 1600 inch-pounds in tension.

It is the responsibility of the architect and/or structural engineer, in general responsible charge of the project, to sign and submit the necessary calculations that show the adequacy of the wall where the TV arm and mounting bracket will be installed. Drill four, 3/8" diameter holes that correspond to the wall bracket mounting bolt pattern to a minimum depth of 2 1/2". Install four 3/8" x 2 1/2" HILTI KWIK BOLT cement anchors. Position the wall bracket over the exposed mounting holes. Thread bolt and washer through bracket and into hole. Tighten all bolts.

- FABRICATED BACKING PLATE** – A fabricated plate is used that holds welded-on or pressed-in studs. The studs (1/4"-20UNC-2A) would be located on hole centers that coincide with the wall bracket. The plate is then secured to the wall studs. A prefabricated plate PDI-254 or PDI-254-24 is available from PDI see figure 5. Consult the backing plate instructions packed with each plate for installation details.

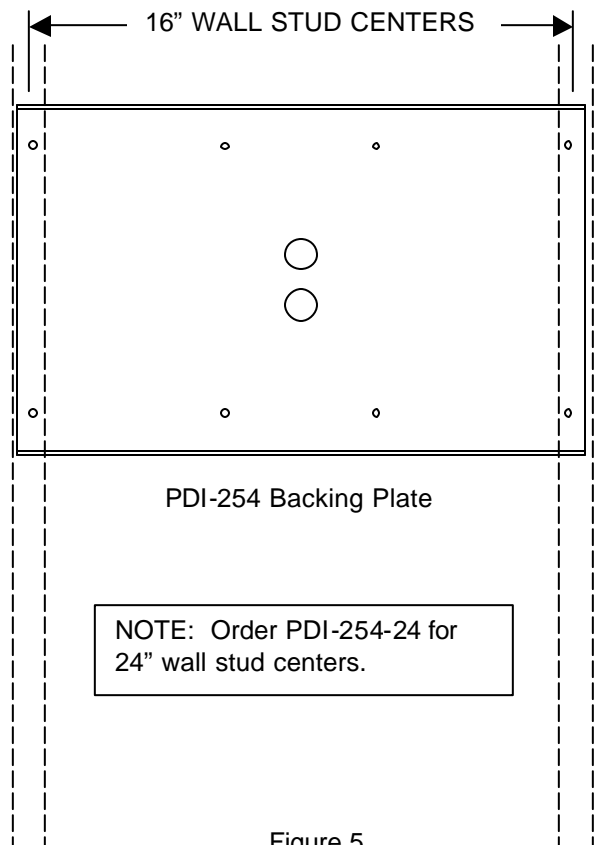

Figure 5.