

DETAIL B  
SCALE 1 : 4

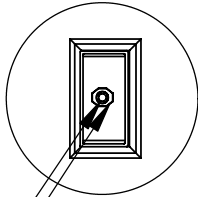

1/4-20 Hex Nut  
1/4-20 x 3/4" Setscrew  
Depth of screw determines  
range of swivel adjustment.

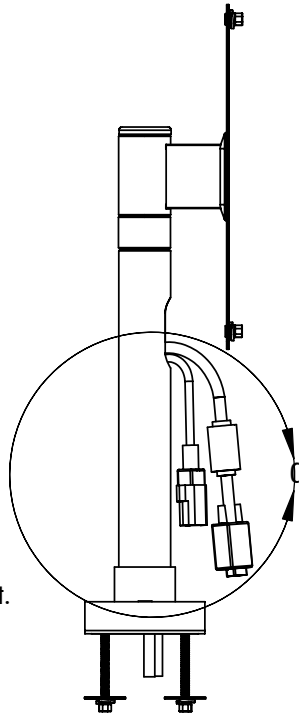

DETAIL C  
SCALE 1 : 4

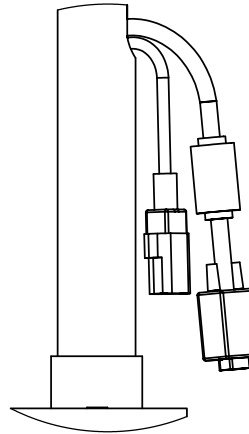

## FSF12 Installation Instructions

9. Adjust the Hex Head Screw in the top of the mount to increase the swivel friction. This screw is pre-tensioned but may need increased tension depending on the weight of the screen.
10. Adjust the amount of swivel allowed by removing the 1/4-20 nut in the middle of the face plate and screwing in the adjustment setscrew.
11. Secure the setscrew with the 1/4-20 hex nut to prevent it from backing off.
12. Run the electrical cord and monitor cord through the pipe. Then, follow the instructions provided for attaching the flat screen mounting bracket (not shown here).

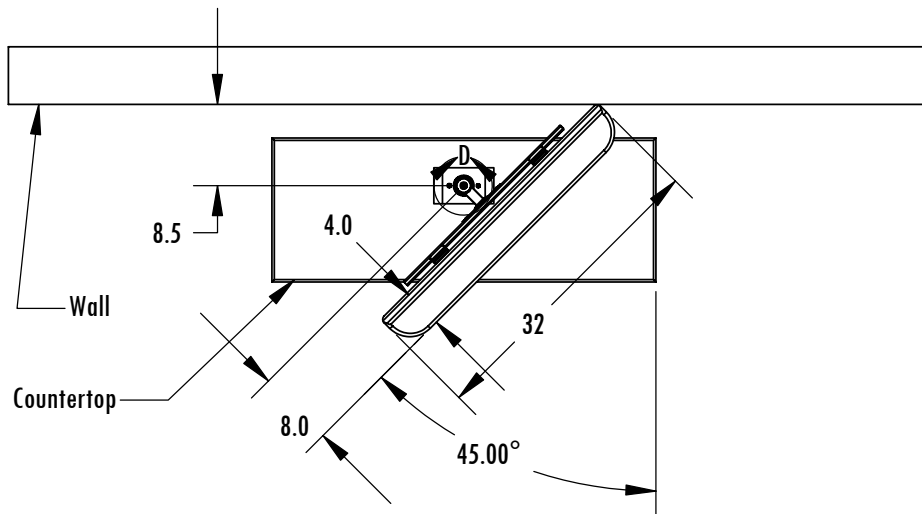

DETAIL D  
SCALE 1 : 4

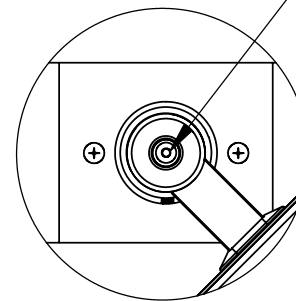

1/4-20 x 1" Hex Head Screw  
Swivel Tension Adjustment