

**Field
Service
Manual**

Ten Tap AC Central

High Efficiency Power Supply



Model PDI-772HE 10 Tap AC Central Hospital Grade Central Power Supply

Better Solutions Are Within Reach®

PDI
Communication
Systems, Inc.
40 Greenwood Lane
Springboro, Ohio
45066

PH: 937-743-6010
FX: 937-743-5664

<http://www.pdiarm.com>

Graphical Symbols



This lightning flash with arrowhead symbol, within an equilateral is intended to alert the user of the presence of uninsulated “dangerous voltage” within the product’s enclosure that may be of sufficient magnitude to constitute a risk of electric shock to persons.



The exclamation point within an equilateral triangle is intended to alert the user of the presence of important operating and maintenance (servicing) instructions in the literature accompanying the appliance.

This service manual contains various CAUTIONS and WARNINGS indicated by triangular warning symbols, which should be read and understood in order to minimize the risk of personal injury to service personnel and customers. The possibility exists that improper service methods may damage the equipment or result in property damage or user injury. It also is important to understand that these CAUTIONS and WARNINGS are not exhaustive. PDI could not possibly know, evaluate and advise the service industry of all conceivable methods in which service might be done or of the possible hazardous consequences of each method. Accordingly, a servicer who uses a service procedure or tool which is not recommended by PDI must first satisfy themselves thoroughly that neither their safety nor the safe operation of the equipment will be compromised by the service method selected.

Product Safety Servicing Precautions

1. **MODIFICATIONS** Do not attempt to modify this product in any way without written authorization from PDI. Unauthorized modifications will not only void the warranty, but may lead to your being liable for any resulting property damage or user injury.
2. **POWER** This unit supplies a NEC Class 2 level power voltage suitable to power a CSA Certified / UL Approved Hospital Grade Television. This supply provides an AC output voltage only and is not suitable for DC powered televisions.
3. **REPAIRS** Due to the specialized nature of this power supply, field servicing is not recommended. The power supply must be removed and returned to the manufacturer for servicing.

Input Voltage	Current
120 VAC	10 Amps Maximum

Output Voltage	Current
28 VAC	3 Amps Maximum

Field Troubleshooting

Troubleshooting involves determining the fault and then taking corrective action. The fault is either external to the supply or a fault inside the supply. If the fault is internal (inside) the supply, remove from service and replace with a know good working central power supply.



CAUTION 28 VAC is present on the coax cable during this measurement.

FAULT	CORRECTIVE ACTION
All TVs are dead.	<ol style="list-style-type: none"> 1. Verify AC line voltage to the supply. 2. Power supply main circuit breaker tripped. Reset. NOTE: A tripped main breaker indicates an overload condition and may require removing the power supply from service for further bench troubleshooting. 3. Verify AC output voltage (28 VAC) at each "F" output fitting at the central power supply. If an "F" output fitting is dead. Reset the corresponding output circuit breaker if tripped. If resetting the output circuit breaker does not clear the fault, remove the central power supply from service. An internal fault has occurred that requires bench repair.
Individual TV dead.	<ol style="list-style-type: none"> 1. At the TV, open the cover on the support arm. Slide the rubber boot and expose the "F" barrel connection. Disconnect the "arm side" coax and verify AC voltage present on the supply side of the coax. If AC power supply voltage (28 VAC) is present, a fault has occurred in the TV. Replace the TV. 2. At the central, check the corresponding output circuit breaker. If tripped, reset the output circuit breaker. NOTE: A tripped output circuit breaker may indicate either a TV or coax cable fault.
Main circuit breaker will not reset.	<ol style="list-style-type: none"> 1. Remove from service and replace with a know good working central power supply.
Output circuit breaker will not reset.	<ol style="list-style-type: none"> 1. Disconnect the coax cable from the suspect "F" output connector. Reset the output circuit breaker. If the circuit breaker holds, a coax wiring or TV fault has occurred. 2. With the coax cable disconnected, reset the output circuit breaker. If the circuit breaker trips an internal fault has occurred that requires bench repair. Remove from service and replace with a know good working central power supply.

<i>FAULT</i>	<i>CORRECTIVE ACTION</i>
TV picture noisy on all TVs.	<ol style="list-style-type: none"><li data-bbox="797 260 1372 411">1. At the central power supply, remove the input RF cable and check the signal level. The central power supply requires a minimum RF level of +24 dbmv for a healthy RF signal level at each TV.<li data-bbox="797 443 1372 745">2. Unplug the central power supply power cord, remove each output coax and check the signal level at each "F" output. With a know RF input signal level to the central power supply "RF IN", check for an insertion loss of 14 dbmv at each "F" output. Any insertion loss greater than 14 dbmv indicates a fault. Remove from service and replace with a know good working central power supply.
TV picture noisy on one TV.	<ol style="list-style-type: none"><li data-bbox="797 779 1372 1024">1. At the TV, open the cover on the support arm. Slide the rubber boot and expose the "F" barrel connection. Disconnect the "arm side" coax and verify an RF signal level equal to or greater than 0 dbmv. Caution AC voltage is present on the coax during this measurement. If the signal level is less than specified check for coax wiring faults.<li data-bbox="797 1056 1372 1136">2. If the signal level is greater than 0 dbmv, replace the "F-61" barrel connector and check the TV's picture.<li data-bbox="797 1167 1372 1199">3. If the TV's picture is noisy, replace the TV.

Field Replacement

The PDI-772HE is a specialized, high-efficiency power supply that incorporates very high bandwidth RF circuitry. Unique to the design, a diplexed RF circuit that provides RF CATV signal and 28 VAC power to 10 discrete outputs rather than the 8 binary style outputs found commonly in passive RF distribution networks.

Due to the specialized nature of this power supply, in-field servicing is not recommended. The power supply must be removed and returned to the manufacturer for servicing.

REMOVAL

1. Disconnect the AC line cord.
2. Remove four screws from the access cover.
3. Disconnect all RF output coax cables. Close access cover and secure with screws.
4. Loosen and remove the four power supply mounting bolts.
5. Remove the supply.

REPLACEMENT

1. Position the supply over the mounting holes. Install and tighten the four mounting bolts.
2. Remove four screws from the access cover. Connect the output coax cables.
3. Connect the RF input coax cable.
4. Close access cover and secure with screws.
5. Connect the AC line cord to power the supply.

Factory Service

To obtain factory service for the central power supply:

1. Call **1-800-628-9870 X223** and request a "Return Authorization" form. The form is faxed or emailed immediately.
2. All form information must be completed in order to be assigned a Return Authorization number.
3. Fax the completed "Return Authorization" form to 513-743-5664.
4. Package the supply in its original shipping box. All returned items must be insured. Please include a copy of the "Return Authorization" form with all shipments and reference the RA# on the shipping label or box.

All non-warranty repairs require a purchase order.

All returned items must be insured.

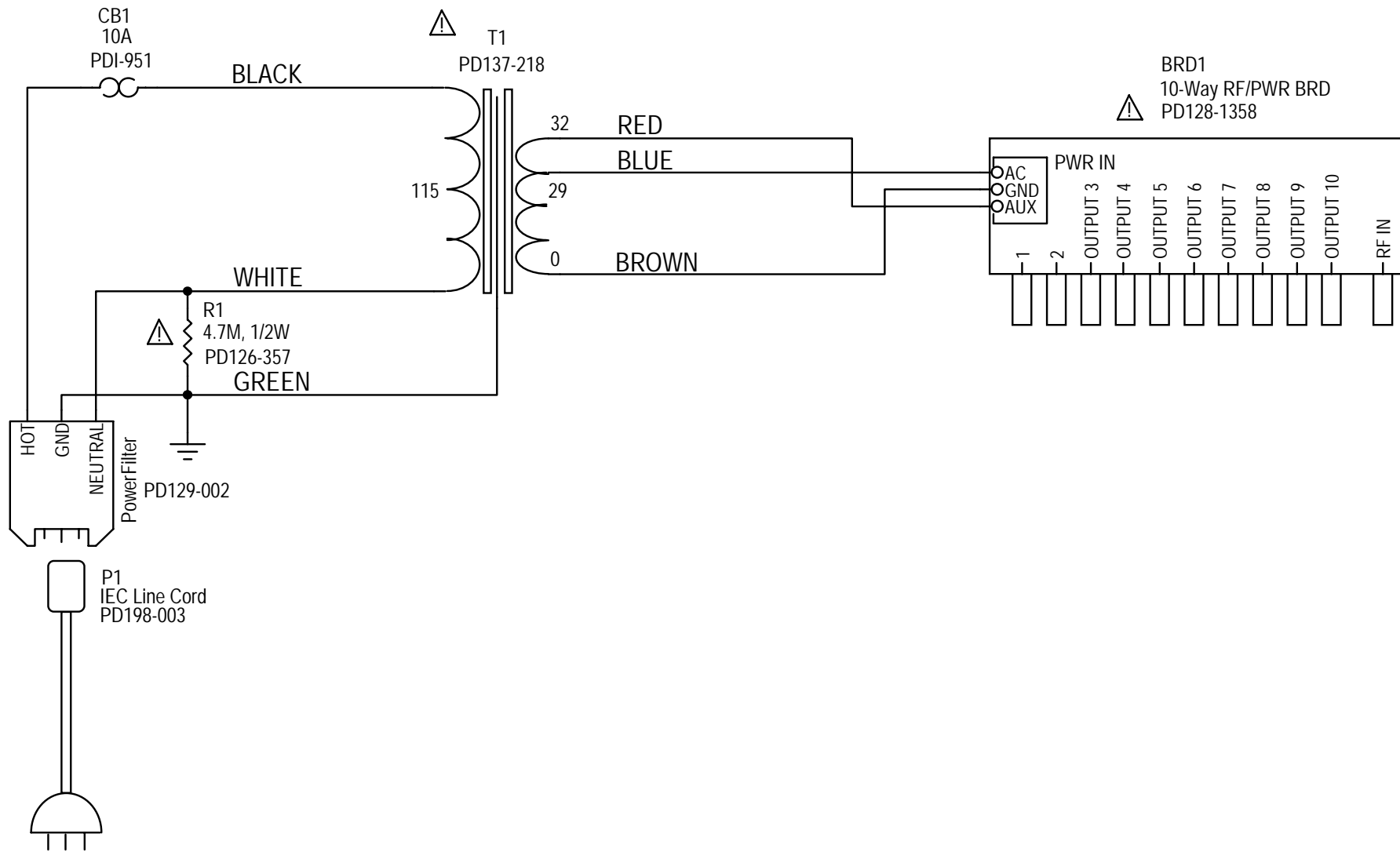

⚠ Indicates a critical component. Replace only with same type specified. Do NOT substitute.

PDI Communication Systems claims proprietary right to the material disclosed hereon. This drawing is issued in confidence for engineering information only and may not be reproduced or used to manufacture anything shown hereon without permission from PDI to the user. This drawing is loaned for mutual assistance and is subject to recall at any time. Copyright 2003©PDI. All rights reserved.

Rev REV 1	ID PDI-772HE
Date: 22 DEC 2003	Page: 1 of 1

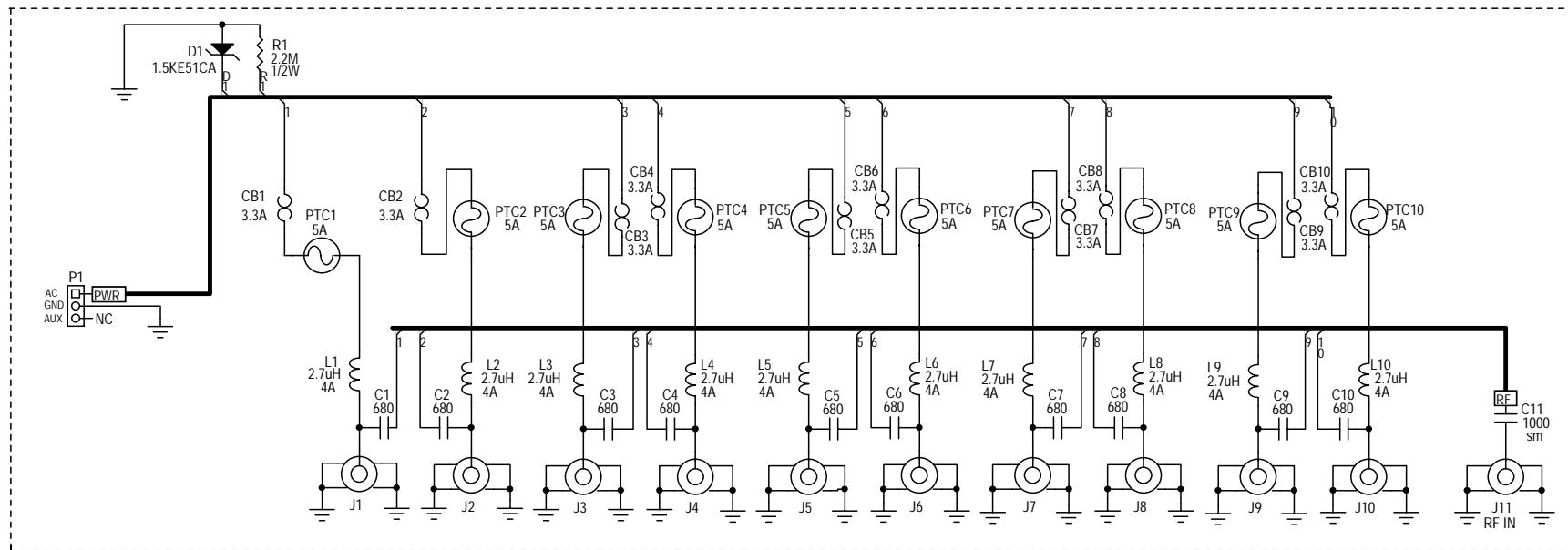

NOTE: For clarity the RF Splitter network not shown.

PARTS LIST (Replacable components only)

- CB1-CB10 3.3A CIRCUIT BREAKER, SCHURTER T11-211-3.3A
- PTC1-PTC10 5A, PTC, RAYCHEM RUE500
- D1 51V CLAMP DIODE, 1.5KE51CA
- R1 2.2M, 1/2W RESISTOR

PDI Communication Systems claims proprietary right to the material disclosed herein. This drawing is issued in confidence for engineering information only and may not be reproduced or used to manufacture anything shown herein without permission from PDI to the user. This drawing is loaned for mutual assistance and is subject to recall at any time. Copyright 2003©PDI. All rights reserved.

10 WAY RF/PWR BOARD	
Rev	ID
REV D	PD128-1358
Date: 13 FEB 2003	Page: 1 of 1